

nobi

Nobita

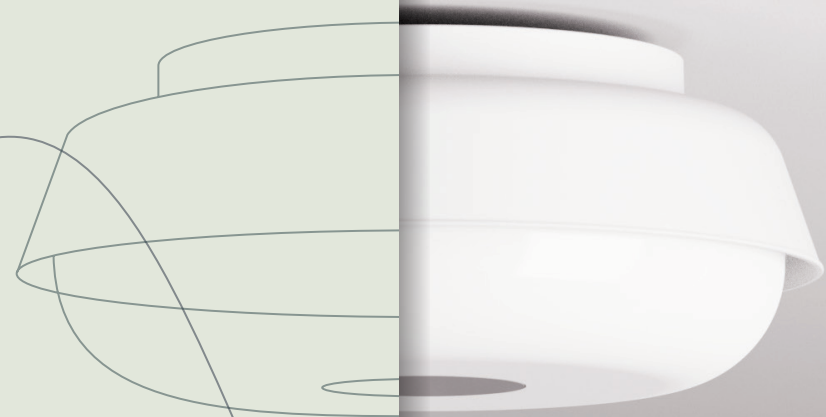

INSTALLATION AND USER MANUAL

Version 1.0

nobi

Nobita

Congratulations on your Nobita.

The purpose of this document is to provide you with all the necessary information to ensure a smooth installation process. Installation of your Nobita brings us one step closer to creating a safer and happier living environment.

Be sure to check out our installation videos on: nobi.life/installation.

Table of Contents

Installation

This box includes	3
Required installation tools	3
Installation process	4
Mounting preparations	5
Installing Nobita power	6
Attaching the Nobita lamp	8

Onboarding

Pairing the Nobita	11
Safety precautions	13
Disposal of your old product	13
Symbols	14
Labels	15
Environmental Conditions	15
Contact information	16

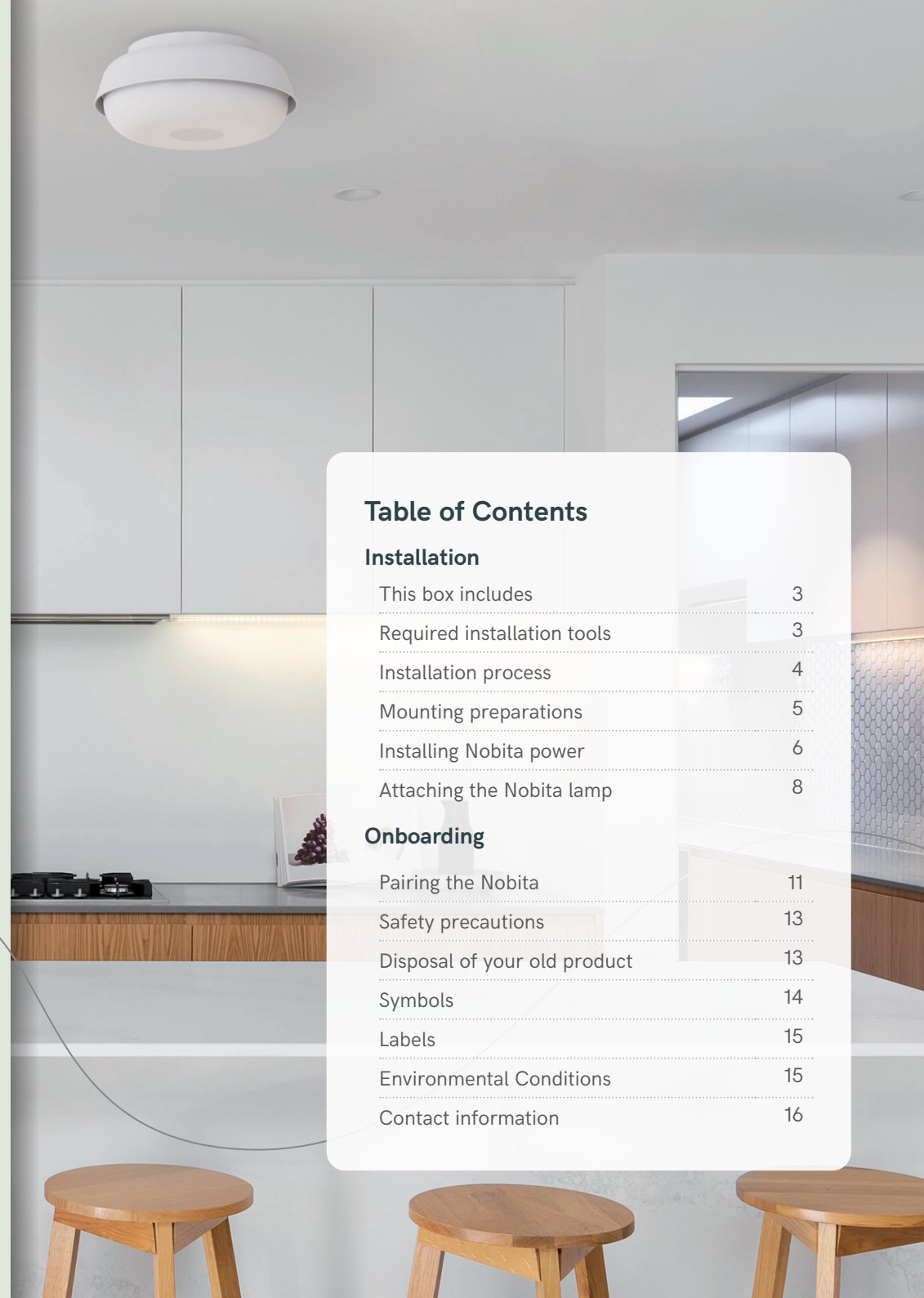
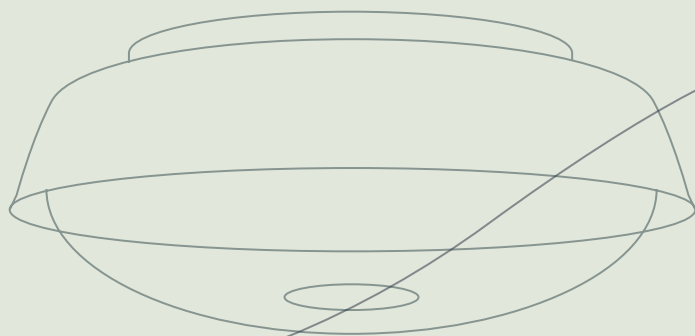

This box includes:

- 1 Nobita lamp
- 1 Nobita power

For this installation, you'll need:

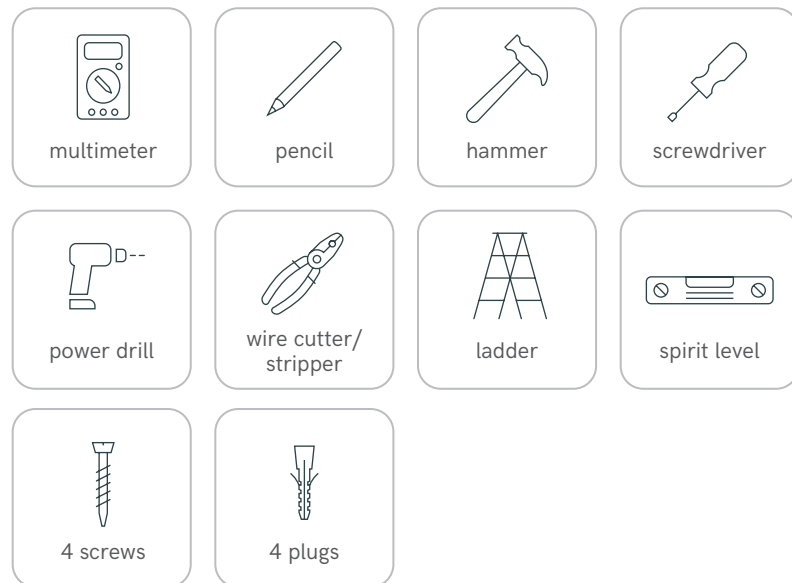

Installation Process

- Mounting the Nobita should take approximately **30 minutes**
- Mounting the Nobi wall switch takes around **15 minutes**
- The onboarding process, including connecting any accessories (such as blood pressure meters or scales), should not exceed **10 minutes**

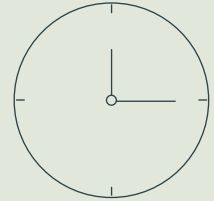

NOTICE: After installation and onboarding, the Nobita may undergo an update, the duration of which depends on your WiFi network's capacity. The size of the update can be as large as 1 GB. The update occurs in the background and has no impact on Nobi's operation, remaining entirely inconspicuous to the user.

Mounting Nobita

Preparations

- 1 Locate the main circuit breaker (it's advisable to do this in advance) and switch off the electrical power. Switch the main circuit breaker (usually a pair) to the OFF position to cut off the electrical power. To cut off power to individual rooms or circuits, switch the branch circuit breaker to the OFF position.

Before proceeding to the next step, confirm that the circuit breaker is switched off using a multimeter.

- 2 Take the Nobita lamp and the Nobita power out of the box and place them on a flat surface to prepare for installation.
- 3 Remove the current ceiling light fixture (if present), exposing 3 electrical wires: ground, neutral and switched line. Make sure you can identify each wire correctly. Usually, the switched line is brown or black, neutral is blue, and ground is green/yellow.

Note: These colours may differ depending on the country or local electrical installation regulations and practices.

Notice: The switched line must be bridged to the ground wire behind the wall switch that controls the lighting point where the Nobita will be installed. This ensures a constant 230V power supply to this point. The Bluetooth component that controls the Nobi LED light will be installed behind the wall switch.

More information and installation videos are available on: nobi.life/installation

Installing Nobita power

- 4 Hold the Nobita power against the ceiling and mark the 4 drill holes with a pencil.

Note: Marking the holes is critical to the accuracy and ease of the subsequent steps; it requires attention.

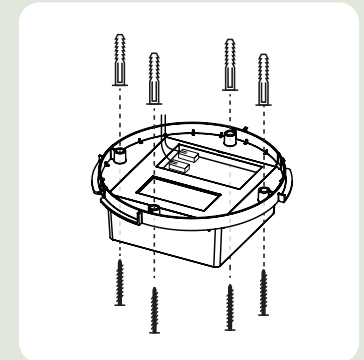

- 5 Drill the holes at the designated points. Ensure that the holes' depth is suitable for the screws and plugs. Carefully tap the plugs into the drilled holes. Use all four screws for a sturdy installation.

- 6 Now connect the electrical wires to the Nobita power. Connect the ground and neutral wires to the appropriate connectors on the Nobita power. The ground wire should not be connected.

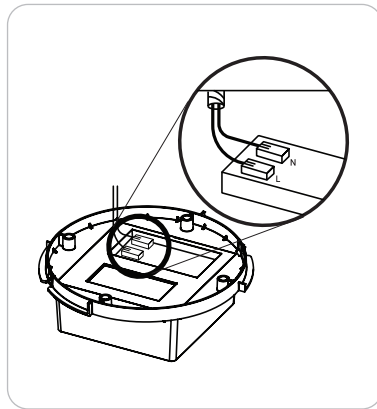

Caution: The neutral and ground wires must not be connected to the same connector.

- 7 Mount the Nobita power with the four screws. Tighten the screws, ensuring the Nobita power is firmly fixed to the ceiling.

- 8 The circuit breaker can now be switched back on.

A small green light will illuminate.

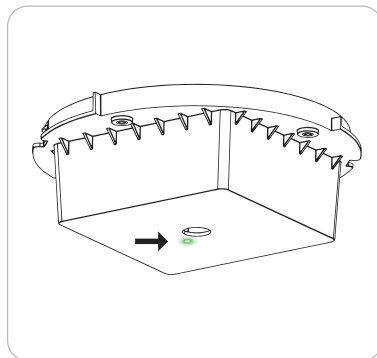

Attaching the Nobita lamp

- 9 Now you can connect the lamp to the Nobita power.

Place the Nobita lamp over the Nobita power, turn it 90 degrees to the right, and then pull down until you hear a click.

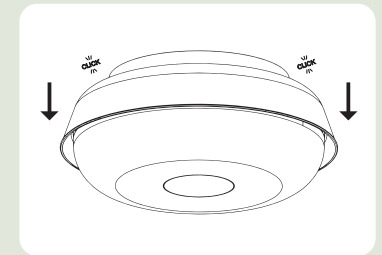
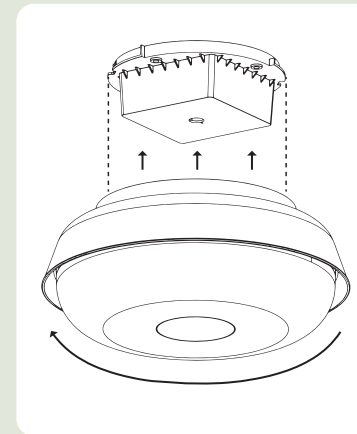

- 10 It will first flicker white and then flash blue.

- 11 Remove the plastic on the underside of the lamp.

Onboarding of the Nobita



Before you begin the onboarding process, contact your local distributor and download the app.



Pairing the Nobita

Before you begin the onboarding process, contact your local distributor and download the app. They will help you configure your account. Once your account is configured, you are all set for a successful onboarding.

Before you can proceed with a Nobita, note that an onboarded Nobi pendant or ceiling must first be installed in the same housing unit where you intend to install the Nobita. The Nobita can be installed in both a bathroom, kitchen or restroom.

Open the app:

- 1 In the menu, click on "housing units".
- 2 Find the relevant housing unit.
- 3 Click on 'edit'. Click on 'rooms'. Click on "add".
- 4 Select the type of room.
- 5 Click on "Link the lamp".
- 6 Click on "Start link".
- 7 A list of available lamps is displayed. Choose the correct lamp based on the six-character hardware code found on the sticker.
- 8 Click on "Link".
- 9 The pairing process goes through the following steps:
 - set up WIFI connection
 - connect to Nobi Cloud
 - confirmation Nobi.
- 10 The lamp has been successfully added.

In the event of an error, go to the app, click on "contact support" and contact Nobi with a ticket.

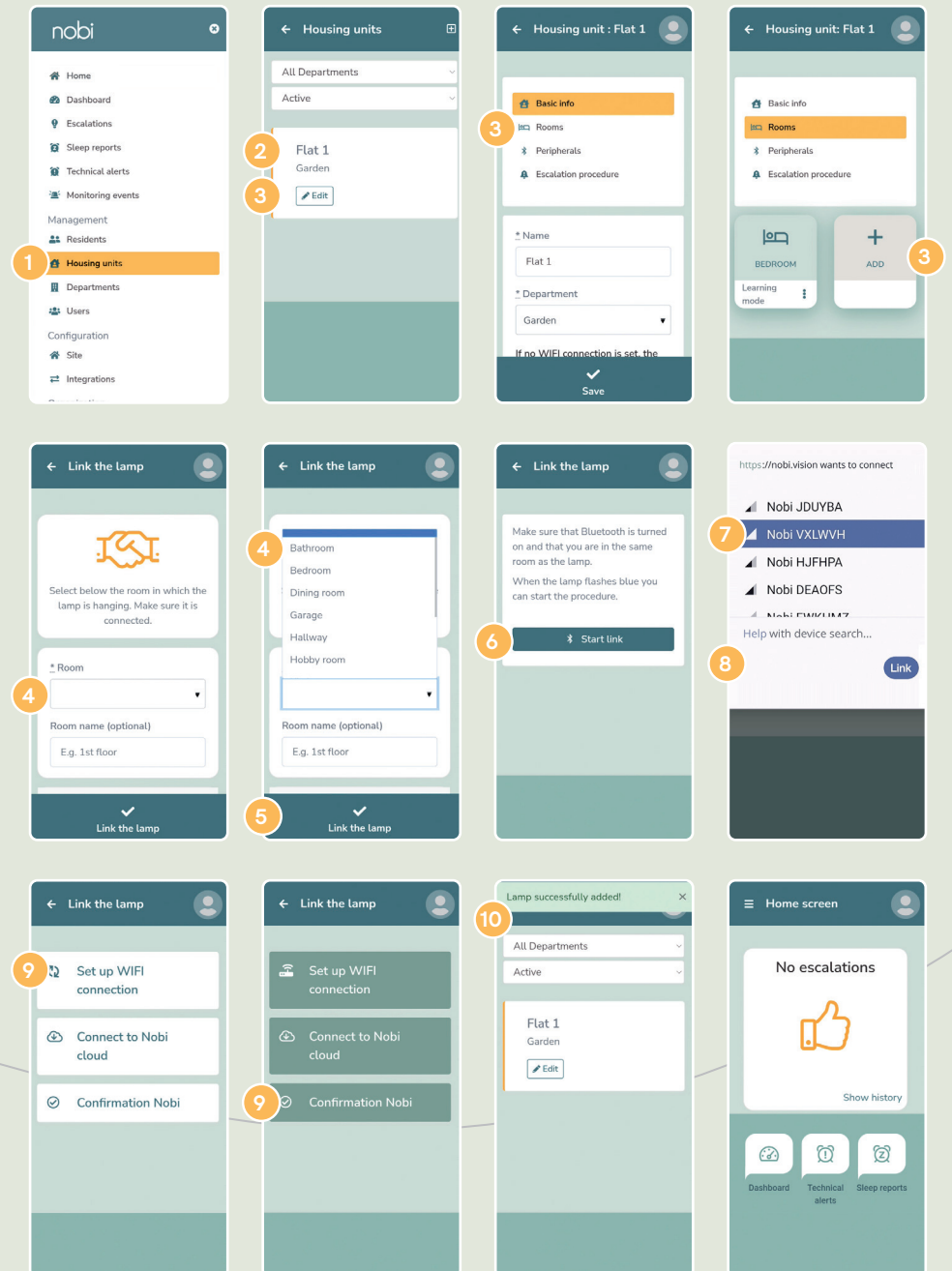

Safety precautions



Read the following safety precautions carefully before installing the Nobita.

- Take care when installing the Nobita as there is a risk of electric shock.
- This product must be installed in accordance with the applicable installation code by a person familiar with the construction and operation of the product and the hazards involved.
- The Nobita must be installed in an electrical circuit that contains a fuse with a minimum contact separation of 1/10" (3 mm).
- Do not install the Nobita in a closet.
- Do not install the Nobita in a bathroom or WC.
- The Nobita is designed for indoor use only.
- The Nobita must be mounted on the ceiling.
- The light source in this luminaire should only be replaced by the manufacturer, its service agent or a similarly qualified person.
- Install the Nobita out of arm's reach.

Disposal of your old product: Your product is designed and manufactured with high quality materials and components that can be recycled and reused. Please find out about your local collection system for electrical and electronic products.

Please follow your local regulations and do not dispose of your old product with your regular household waste. Correct disposal of your old product will help prevent potential negative consequences for the environment and human health.

Symbols

	Consult manual before use		FCC marking
	Caution, risk of electric shock		CE marking
	Class II		UK Conformity Assessed
	Class III		Location of manufacturing
	Do not stare at the light source		Recycling
	Nobita mount use only		Warning sign
	Emits IR light		Read manual before use
	Indoor use only		DC polarity
	Caution is needed when installing and using this device; consult the manual before use		

Labels

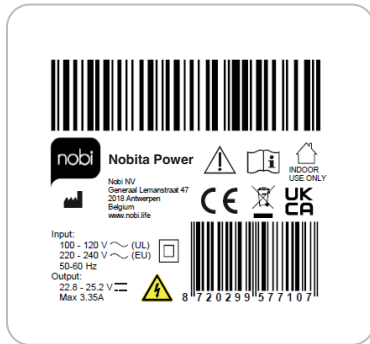

Nobita Power



Nobita Smart Lamp

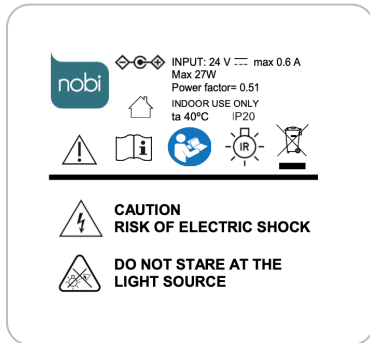

Environmental Conditions

- Operating temperature: 50°F to 104°F
- Operating humidity: 15% to 95% non-condensing
- Atmospheric pressure: +660 to +1060 hPa and maximum 6560 ft (2000 m) altitude

Do you have any questions? Let us assist you!



General questions?

Take a look at our frequently asked questions and answers:

nobi.life/en/frequently-asked-questions

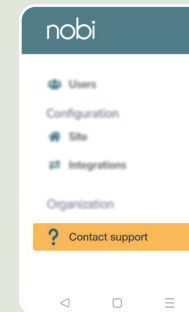

Question after onboarding?

- Go to the app
- Open the menu
- Click on "contact support"
- Contact Nobi with a ticket

Nobi, proudly supported by:



www.nobi.life